

Infrared thermometer

Item-No. 10 09 12 IR 650-12D

Item-No. 10 09 17 IR 800-20D

Introduction

Dear customer,

Thank you for making the excellent decision to purchase this Voltcraft® product.

You acquired a high-quality product with a name that stands for outstanding products in the field of measuring, charging and power technology, which excel by professional competence and permanent innovation.

With Voltcraft®, you will be able to cope even with difficult tasks equally as an ambitious hobby user or as a professional user. Voltcraft® offers reliable technology combined with exceptional value for money.

Therefore, we are absolutely sure: starting to use Voltcraft will also be the beginning of a long, successful relationship.

And now enjoy your new Voltcraft® product!

Intended Use

The infrared thermometer is a measuring device for contactless temperature measurement. It determines the temperature by infrared energy that is emitted by an object and by its emission ratio. It is especially useful to measure the temperature of hot, difficult accessible or moving objects. The infrared thermometer measures the surface temperature of an object. It cannot measure through transparent surfaces like glass or plastics. Its temperature measuring range reaches from -50°C to 650°C (IR 650-12D) and from -50°C to 800°C (IR 800-20D), respectively. A 9V block battery is required for voltage supply.

This product is EMC-tested and meets the requirements of the applicable European and national guidelines. Proof of CE conformity has been established and the corresponding declarations are obtainable from the manufacturer.

Uses other than those described above are not permitted. They can lead to damage to the product. Moreover, it will cause danger such as short-circuit, fire, electric shock, etc.. Read the operating instructions carefully and keep them for later reference.

Features

- Dual target laser with focal point
- Integrated alarm function for upper and lower alarm value with optical and acoustic signalling.
- Storage of the maximum temperature during measurement
- Permanent measuring function
- Adjustable emission ration from 0.10 to 1.00
- Optional background illumination of the display

Scope of delivery

- Infrared thermometer
- Carry bag
- 9-V compound battery
- Operating Instructions



The warranty will lapse in the event of damage caused by failure to observe these safety instructions! We do not assume any liability for material and personal damage caused by improper use or non-compliance with the safety instructions! An exclamation mark indicates important notes in these operating instructions that should always be observed.

For safety and approval reasons (CE), the unauthorized conversion and/or modification of the product is prohibited.

The appliance should not be exposed to strong vibration or heavy mechanical stress.

Do not expose the product to electromagnetic fields, extreme temperatures, direct intensive solar radiation or moisture.

Do not expose the product to high humidity or liquids. On outdoor use the appliance must only be operated under respective weather conditions and only with the appropriate safety devices.

Moisture, dust, fume and/or vapours can affect the optics of the thermometer and thusly the measuring results.

Never use optical instruments and never look directly into laser beam.



Do not point the laser beam at mirrors or other reflecting areas.

Do not point the laser beam directly at persons or animals. Laser radiation may lead to eye or skin injuries.

This product is equipped with a class 2 laser according to EN 60825-1:2007.

Caution: Operating this product or changing the setting differently that suggested by this operating manual can lead to dangerous radiation.

The device should not be taken into operation immediately after it has been brought from a cold ambient temperature into a warm room. Condensate may destroy the device. Likewise can the lense become misty which can lead to mismeasurements. Wait until the product has reached ambient temperature before using it.

If you should have reasons to assume that safe operation is no longer ensured, turn off the device and secure it against accidental activation. Safe operation is no longer ensured, when:

- the device shows visible signs of damage,
- the device no longer functions or
- the product has been stored under unfavourable conditions for a longer period of time,
- the product has been exposed to strong stress during transportation.

The device is not a toy. Keep it away from children and pets!

On industrial sites, the accident prevention regulations of the association of the industrial workers' societies for electrical equipment and utilities must be followed. In schools, training facilities, hobby and self-help-workshops, the operation of electric appliances is to be supervising by trained personnel. Maintenance, adjustment, or repair may only be carried out by a specialist/specialised workshop.

If you have questions about handling the measuring device, that are not answered in this operating instruction, our technical support is available under the following address and telephone number:

Voltcraft®, 92242 Hirschau, Lindenweg 15, phone 0180 / 586 582 723 8

Controls

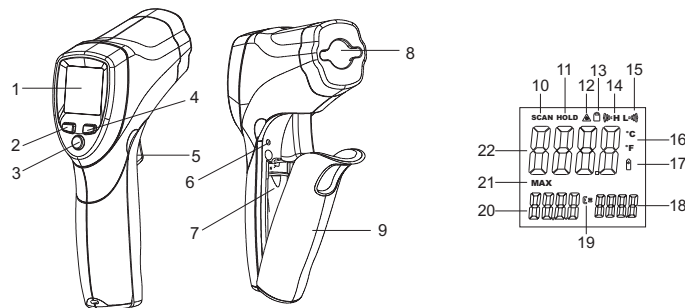

1. Display
2. "UP" button
3. "MODE" button
4. "DOWN" button
5. Measuring button
6. °C/°F conversion
7. Battery compartment
8. Laser outlet / measuring hole
9. Battery compartment cover
10. "Scan", measuring display
11. "Hold", display for temporary storage of the measuring value
12. Display target laser activated
13. Display permanent measuring function activated
14. Symbol for the upper alarm value
15. Symbol for the lower alarm value
16. Measuring unit (°C or °F)
17. Symbol empty battery
18. Emission ratio indication
19. Symbol for emission ratio
20. Maximum temperature indication
21. Symbol for maximum temperature
22. Measuring value

Inserting/Replacing the Batteries



Make sure that the polarity is correct when inserting the batteries. Remove the battery, if you are not going to use the device for a while, to prevent damage from leaking. Leaking or damaged batteries/rechargeable batteries can cause acid burns upon contact with skin. Thus, you should wear protective gloves when handling damaged batteries/rechargeable batteries.

Keep them out of reach of children. Do not leave batteries lying around. There is the risk that the batteries may be swallowed by children or pets. Replace all batteries at the same time.

Do not dismantle batteries and avoid short-circuits and contact to fire. Never charge conventional, non-rechargeable batteries. They might explode.

Replace the battery if the empty battery symbol (17) is shown in the display.

1. Fold open the battery compartment lid (9) opening the battery compartment (7).
2. Remove the worn battery from the battery clip and connect a new battery of the same type with the correct polarity to the battery clip. The battery clip is constructed to only have the battery connected with the correct polarity. Do not use force when plugging in!
3. Close the battery compartment (7) by closing the battery compartment lid (9).

Operation

Operating principle

IR thermometers measure the surface temperature of an object. The sensor on the device records the heat radiation from the object which is emitted, reflected and transmitted, and converts this information into a temperature value.

The emission level is a value used to describe the energy radiation characteristics of a material. The higher the value, the more capable the material is of emitting radiation. Many organic materials and surfaces have a degree of emission of approx. 0.95. Metallic surfaces or shiny materials have a lower degree of emission and therefore return inaccurate measuring values. Therefore the emission ratio can be set at the the devices IR 650-12D and IR 800-20D.

Measuring:

1. Direct the measuring hole (8) best vertically on the measuring object. Observe the measuring object not to be smaller than the IR-measuring spot of the device (also refer to IR-measuring spot size).
2. Press the measuring button (5) and hold it down. The measuring value is indicated on the display (22). The displayed value corresponds with the average surface temperature of the IR-measuring spot. During measurement "SCAN" (10) is shown in the display.
3. After releasing the measuring button (5) the last measuring value (22) will be displayed for further 7 seconds for better readout. "HOLD" (11) will also be displayed.
4. 7 seconds after releasing the measuring button (5) the device turns off automatically.
5. When the measuring temperature range is exceeded "—" is displayed.



For determination of the hottest spot of the measuring object you have to "scan" the object with impressed measuring button (5) performing systematic zigzag-movements until you have found the hottest spot. The highest temperature measured is shown in the lower left of the display as Maximum temperature (20).



In order to obtain exact measuring values the infrared thermometer has to be adjusted to the ambient temperature. Allow the device to adjust to the ambient temperature when relocating.



Shiny surfaces affect the measuring result. For compensation, the shiny part of the surface can be covered with adhesive tape or matt black paint. The device is not able to take measurements through transparent surfaces such as glass. Instead, it measures the surface temperature of the glass.



Longer measurements of high temperature with low measuring distance lead to self-heating of the measuring device and thusly to mismeasurement. In order to obtain exact measuring values think of following rule of thumb: The higher the temperature the higher the measuring distance and the shorter the measuring time.

IR measuring spot size - Distance to Spot ratio; D/S

In order to obtain precise measuring results, the object to be measured must be larger than the measuring spot of the IR thermometer. The temperature recorded is the average temperature of the area measured. The smaller the object to be measured, the shorter the distance must be to the infrared thermometer. The precise size of the measuring area is shown in the following diagram. It is also printed on the device. For precise measurements, the object to be measured should be at least twice the size of the measuring spot.

D:S 20:1 IR 800-20D

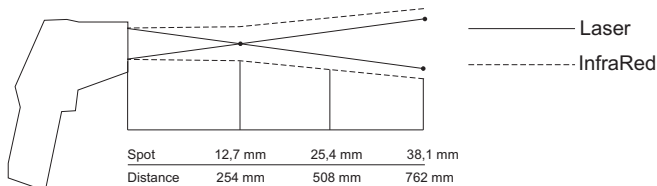

D:S 12:1 IR 650-12D

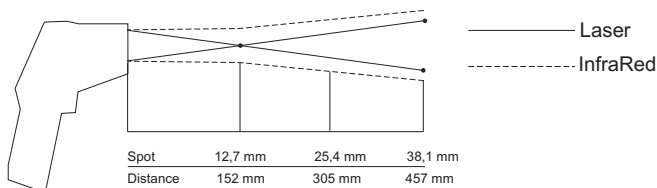

The optimal measuring distance for the devices IR 650-12D and IR 800-20D is the focal point of both target lasers since here is the most precise measuring ensured. The size of the measuring spot in the focal point is 12.7 mm (0.5 inch)

Dual target laser

The dual target laser can be activated and deactivated. Turn the measuring device on by pressing the measuring button (5). Press the button "up" (2). With the laser is activated "Ziellaser Aktiv" (12) is displayed. When pressing the button "up" (2) again the target laser is deactivated, "Ziellaser Aktiv" (12) goes out.

Background illumination

With running measuring device use the button "down" (4) to activate/deactivate the background illumination.

°C/°F conversion between measurement units

Using the switch °C/°F (6) the measuring unit can be switched from °C (degree Celsius) to °F (degree Fahrenheit). The switch is located in the battery compartment (7).

Setting the emission level

The measuring device allows setting the emission ratio. Thus different materials and surfaces can be measured precisely (also refer to Mode of Operation).

1. Turn the measuring device on by pressing the measuring button (5).
2. Press the button "Mode" (3) that often until the symbol for the emission ratio (19) starts flashing in the display.
3. Using the buttons "up" (2) and "down" (4) the emission ratio can be adjusted from 0.10 to 1.00 depending on the respective measuring object.
4. Confirm your input with the measuring button (5) or press the button "Mode" (3) in order to get to the next setting.
5. After turning off the device the set value remains stored.



Right after the technical data you will find a table with typical materials and their emission ratio. Many organic materials have an emission ratio of 0.95. Thus the default setting of the emission ratio is 0.95. To determine the emission ratio of a surface the temperature of the surface to be measured can also be measured with a conventional thermometer and with a special surface sensor. Change the emission ratio of the infrared thermometer until the measuring value (22) matches this of the conventional surface measuring. This, however, is only necessary for highly precise measurements.

Permanent operation (Locking function)

The measuring device is equipped with a locking function for long-term measurements.

1. Turn the measuring device on by pressing the measuring button (5).
2. Press the button "Mode" (3) that often until the symbol for permanent measuring (13) starts flashing in the display.
3. The permanent measuring function can be activated using the buttons "up (2) and "down (4) (Display "ON").
4. As soon as you press the measuring button (5) the permanent measuring function is activated. The measuring device now measures permanently until the measuring button (5) is pressed again. Besides the present measuring value (22) the maximum temperature (20) is also displayed.

Alarm mode

The measuring device is equipped with an alarm function when it exceeds preset temperature values. The alarm is effected by a beeper and by flashing red of the background illumination. Due to this function the measuring device can be used optimally for e.g. controls. The device disposes of two adjustable temperature values (upper and lower alarm value). The alarm is triggered on underrunning the lower alarm value or exceeding the upper alarm value. Those values can be adjusted and activated independently.

To activate the alarm, proceed as follows:

1. Turn the measuring device on by pressing the measuring button (5).
2. Press the button "MODE" (3) as often till the symbol for the upper alarm value (14) is flashing and a temperature value is displayed.
3. Using the buttons "up" (2) and "down" (4) sets the upper alarm value which triggers the alarm on excession.
4. To activate the upper alarm value press the button "MODE" (3) as often till the symbol for the upper alarm value (14) is flashing and "ON" or "OFF" is displayed.
5. The upper alarm value can be activated "ON" or deactivated "OFF" using the buttons "up" (2) and "down" (4).
6. Press the button "MODE" (3) as often till the symbol for the lower alarm value (15) is flashing and a temperature value is displayed.
7. Using the buttons "up" (2) and "down" (4) sets the lower alarm value which triggers the alarm on underrun.
8. To activate the lower alarm value press the button "MODE" (3) as often till the symbol for the lower alarm value (15) is flashing and "ON" or "OFF" is displayed.
9. The lower alarm value can be activated "ON" or deactivated "OFF" using the buttons "up" (2) and "down" (4).
10. After turning off the device the set values remains stored.

Maintenance and Care

Cleaning of the lense:

Remove loose particles with clean compressed air and wipe off the remaining residues using a fine brush. Clean the surface with a lense cleaning cloth or a clean, soft, lint-free cloth. For cleaning of fingerprints and other fat residues the cloth can be moistened with water or lense cleaning solution. Do not use any acidic, alcoholic or other solvents as well as no rough, linty cloth to clean the lense. Avoid to apply too much pressure when cleaning.

Cleaning of the housing

Use water and soap or a mild cleaning agent for cleaning the housing. Do not use abrasive agents or solvents!

Disposal of used batteries!

The end user is legally obliged (Battery Regulation) to return used batteries and rechargeable batteries. Do not dispose of used batteries via the domestic waste!



Batteries/rechargeable batteries containing harmful substances are marked with the symbols shown, to indicate that disposal in the domestic waste is forbidden. The symbols for the relevant heavy metals are: **Cd** = cadmium, **Hg** = mercury, **Pb** = lead. You can return used batteries / storage batteries free of charge to the collection points in your community, our branches or anywhere else where batteries or storage batteries are sold.



You thus fulfil your legal obligations and contribute to the protection of the environment!

Disposal



Old electronic devices are hazardous waste and should not be disposed of in the household waste. When the device has become unusable, dispose of it in accordance with the current statutory regulations at the communal collection points. Disposal in the domestic waste is not permitted! The symbol with the crossed out dust bin on wheels means that this product must be brought to a recycling site for electric scrap for a best possible recycling of the raw materials.

Technical Data

Operating voltage:	9-V compound battery	
Response time:	150 ms	
Spectrum:	8 to 14 μ m	
Emission ratio	0.1 to 1.00 adjustable	
Resolution	0.1 °C	
IR-measuring spot size:	IR 650-12D	12:1
	IR 800-20D	20:1
Laser:	Capacity < 1 mW, laser class 2, Wavelength 630-690 nm	
Operating temperature.	0 to 50 °C	
Operating humidity:	10 - 90 % RH	
Storage temperature:	-10 to 60 °C	
Storage humidity:	10 - 80 % RH	
Weight:	175 g	
Dimensions:	160 x 42 x 82 mm	

Accuracy (at 23 - 25 °C ambient temperature, measuring distance in the focal point of the target laser)

IR 650-12D		
Temperature measuring range:	Accuracy	Reproducibility
- 50 to 20 °C	± 3 °C	± 1.3 °C
20 to 300 °C	$\pm 1.5\%$ of the measured value ± 1.5 °C	$\pm 0.5\%$ of the measured value or ± 0.5 °C
300 to 650	± 2 %	$\pm 0.5\%$ of the measured value or ± 0.5 °C

IR 800-20D		
Temperature measuring range:	Accuracy	Reproducibility
- 50 to 20 °C	± 3 °C	± 1.3 °C
20 to 300 °C	$\pm 1.5\%$ of the measured value ± 1.5 °C	$\pm 0.5\%$ of the measured value or ± 0.5 °C
300 to 800	± 2 %	$\pm 0.5\%$ of the measured value or ± 0.5 °C

Emission ratio of different surfaces



The emission ratios in the table are approximate values. Different parameters like geometry and surface quality can affect the emission ratio of an object.

Surface	Emission ratio
asphalt	0,90 - 0,98
concrete	0,94
ice	0,96 - 0,98
ferric oxide	0,78 - 0,82
soil. humus	0,92 - 0,96
hard plaster	0,80 - 0,90
glass/ceramics	0,90 - 0,95
rubber (black)	0,94
varnish	0,80 - 0,95

Surface	Emission ratio
varnish (matt)	0,97
human skin	0,98
mortar	0,89 - 0,91
paper	0,70 - 0,94
plastics	0,85 - 0,95
sand	0,90
textiles	0,90
water	0,92 - 0,96
bricks	0,93 - 0,96

© Impressum /legal notice in our operating instructions

These operating instructions are a publication by Voltcraft®, Lindenweg 15, D-92242 Hirschau/Germany, Phone +49 180/586 582 7 (www.voltcraft.de). All rights including translation reserved. Reproduction by any method, e.g. photocopy, microfilming, or the capture in electronic data processing systems require the prior written approval by the editor. Reprinting, also in part, is prohibited.

These operating instructions represent the technical status at the time of printing. Changes in technology and equipment reserved.

© Copyright 2011 by Voltcraft®